

NOTES: UNLESS OTHERWISE SPECIFIED

1. SEE DRAWING NO. CB-00285 AND PROCEDURE P-1000 FOR ASSEMBLY AND TEST INSTRUCTION. PROCEDURES AND ASSEMBLY DRAWINGS ARE FOR INTERNAL USE ONLY.
2. ALL TESTING IS PERFORMED IAW BATTERY COUNCIL INTERNATIONAL STANDARDS.
3. DIMENSIONS ARE INCH [MILLIMETER].
4. TERMINAL HARDWARE KIT PROVIDED, PART NUMBER 6923.

REVISIONS			
REV	DESCRIPTION	DATE	APPROVED
D	SEE DCN AGM12100TD	8/10/11	JBT
E	REDESIGNED COVER	5/29/18	PH
F	STANDARDIZED ENVELOPE, ADDED NOTE 4	7/17/20	PH

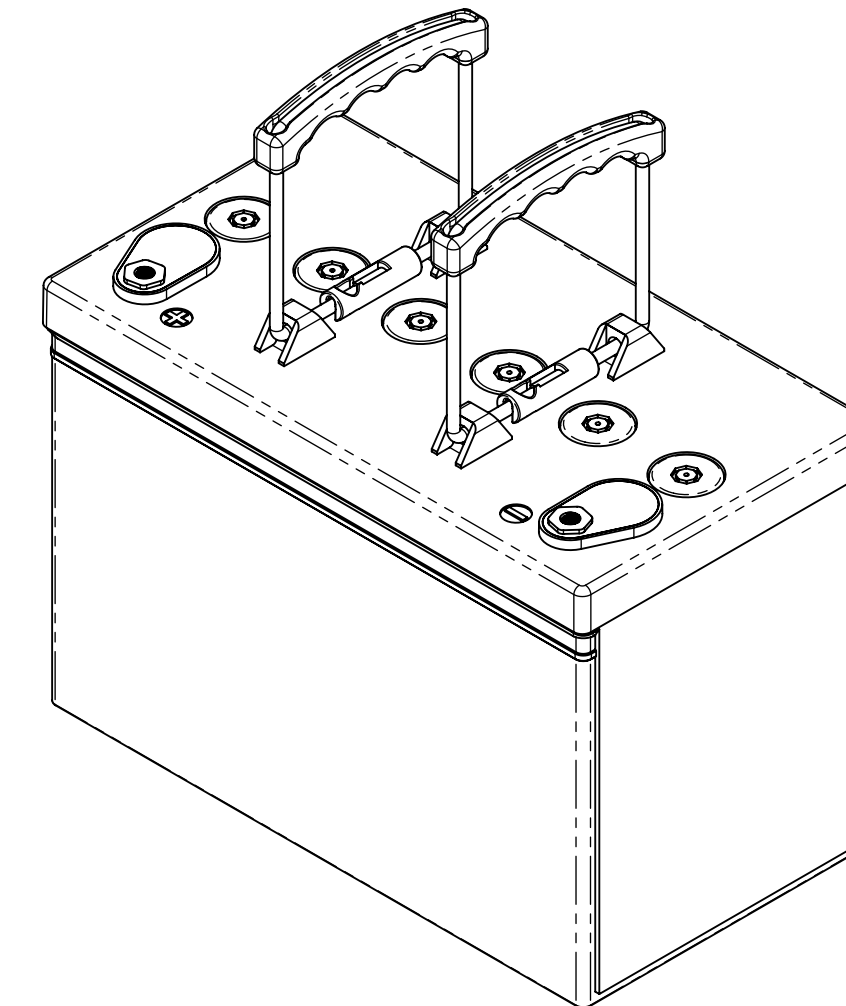
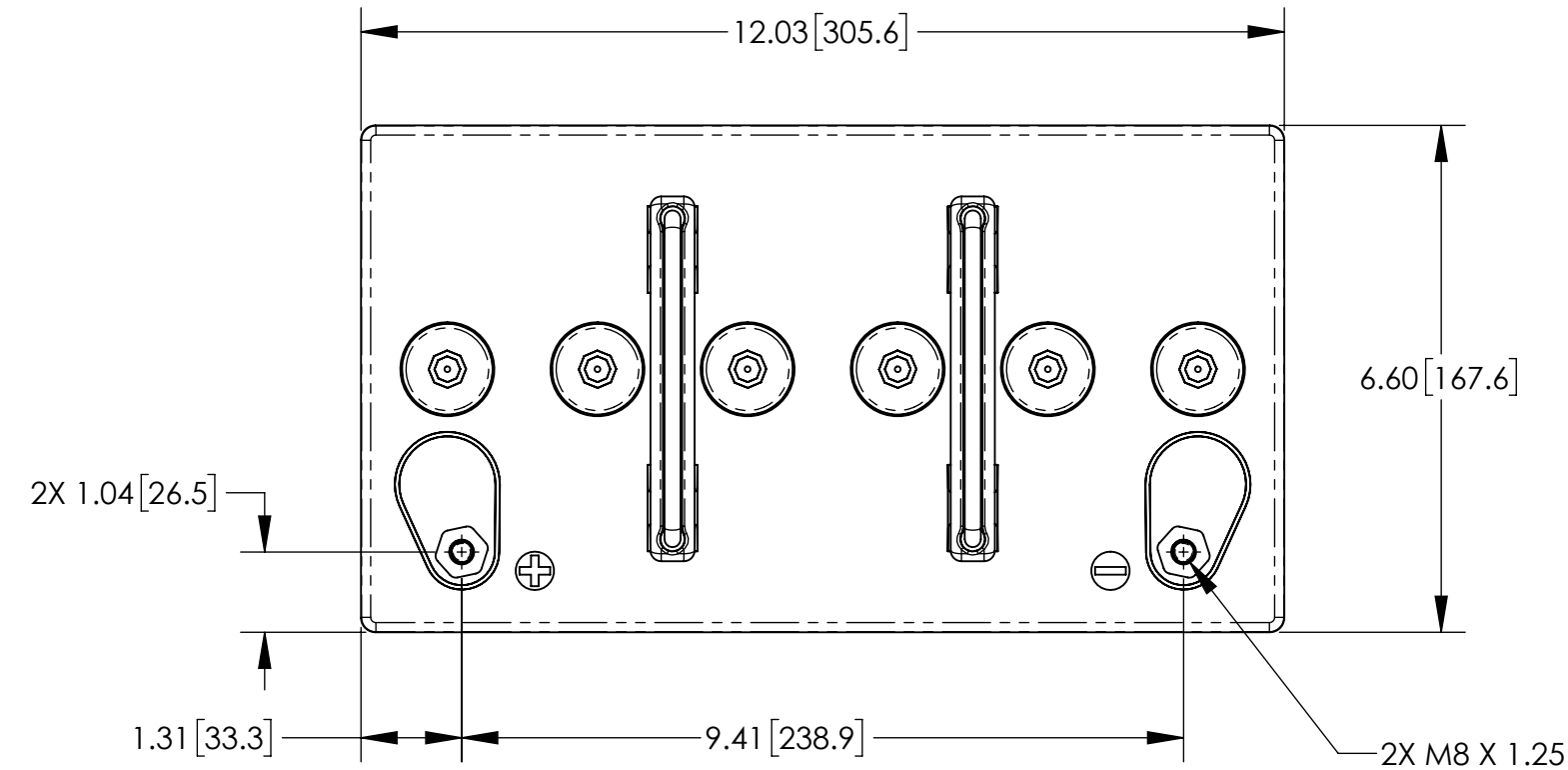

ISOMETRIC VIEW

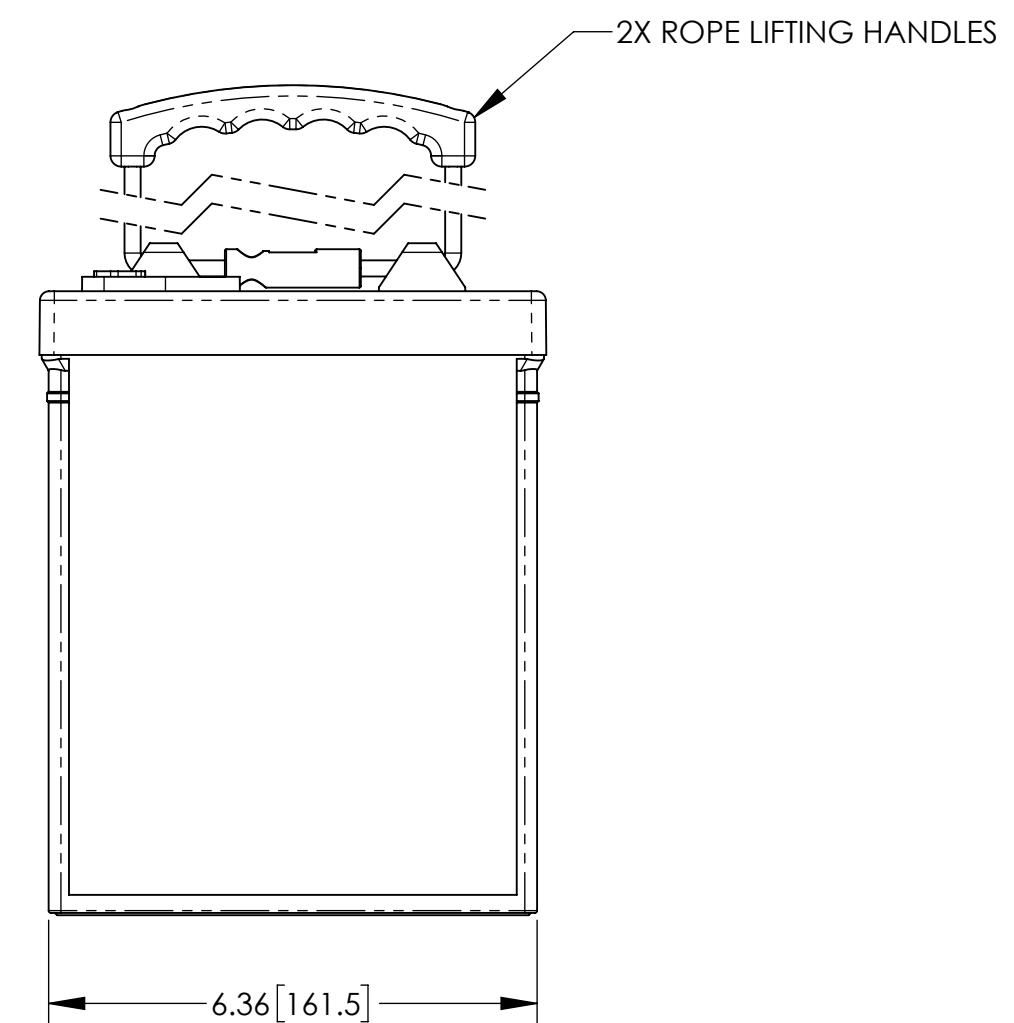
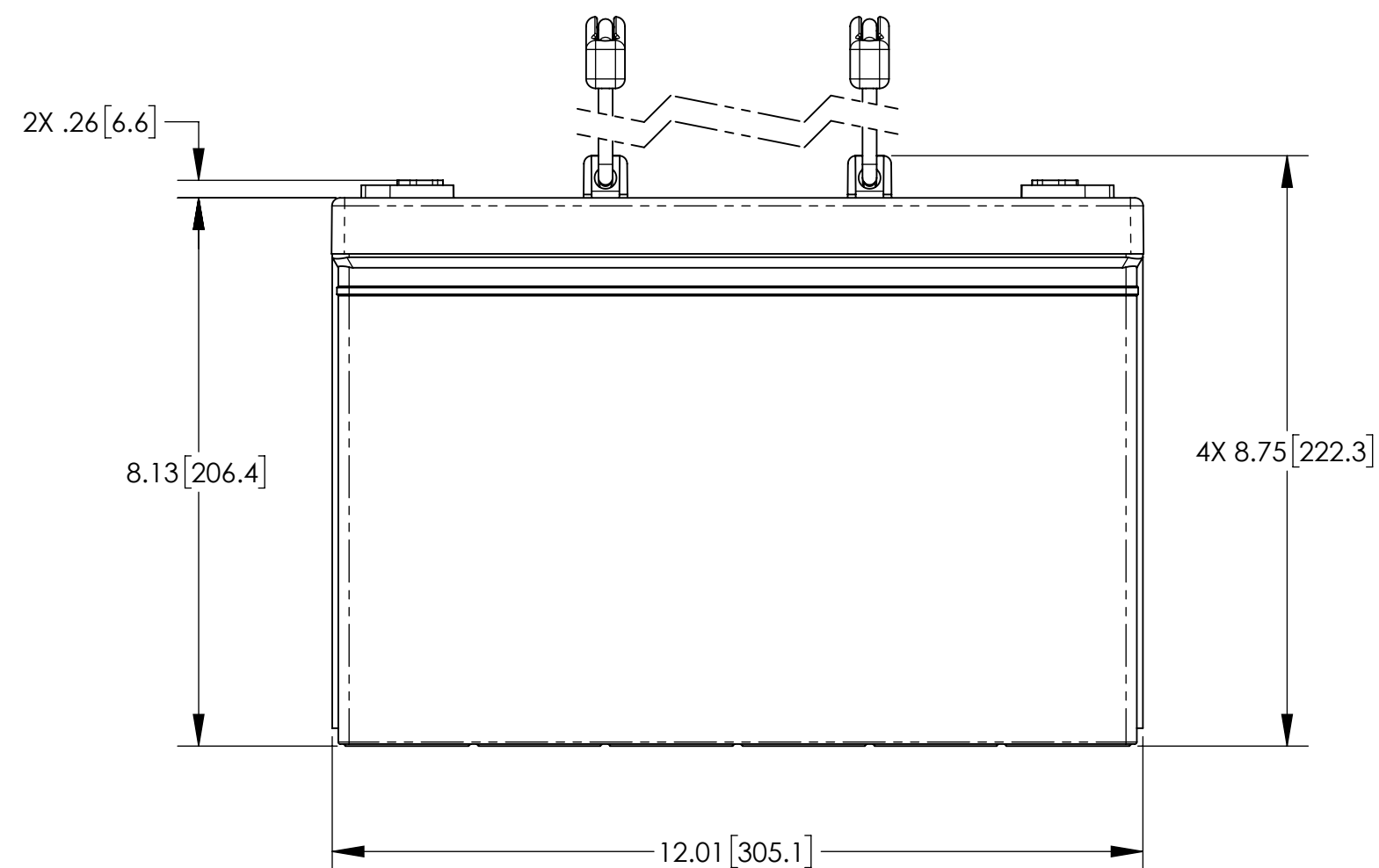

CAPACITY RATINGS	
PART NUMBER	AGM-12100T
NOMINAL WEIGHT	62 LBS [28.1 KG]
AMPERE HOUR CAPACITY @ 20 HOUR 1.75 VOLTS/CELL @ 77°F (25°C)	100 AH
MINUTES OF DISCHARGE @ 25 AMPS 1.75 VOLTS/CELL @ 77°F (25°C)	186 MIN

ENVELOPE DRAWING

UNLESS OTHERWISE SPECIFIED DIMENSIONS ARE IN INCHES TOLERANCES ARE:			CONTRACT NO.		CONCORDE BATTERY CORPORATION 2009 SAN BERNARDINO RD, W. COVINA, CA 91790		
FRACTIONS	DECIMALS	ANGLES	APPROVALS		TITLE		
±1/32	.XX ± .12 .XXX ± .060	±1°	DRAWN	ELH	DATE		BATTERY, 12 VOLT, AGM-12100T
TREATMENT	NONE		CHECKED	S.VALDEZ	03/01/00		
FINISH	NONE		APPROVED	JBT	03/04/00		
SIMILAR TO	CALC WT		ISSUED	DH	7/20/20		
			SCALE	1:2.5	CAGE CODE	63017	DWG NO. AGM-12100T
					REV	F	SHEET 1 OF 1