

NOTES: UNLESS OTHERWISE SPECIFIED

- SEE DRAWING NO. CB-00464 AND PROCEDURE P-1000 FOR ASSEMBLY AND TEST INSTRUCTION. PROCEDURES AND ASSEMBLY DRAWINGS ARE FOR INTERNAL USE ONLY.
- ALL TESTING IS PERFORMED IAW BATTERY COUNCIL INTERNATIONAL STANDARDS.
- DIMENSIONS ARE INCH [MILLIMETER].
- TERMINAL HARDWARE KIT PROVIDED, PART NUMBER 6923.

REVISIONS			
REV	DESCRIPTION	DATE	APPROVED
A	STANDARDIZED ENVELOPE, ADDED NOTE 4	7/21/20	PH
B	REVISED CONTAINER	12/16/21	PH

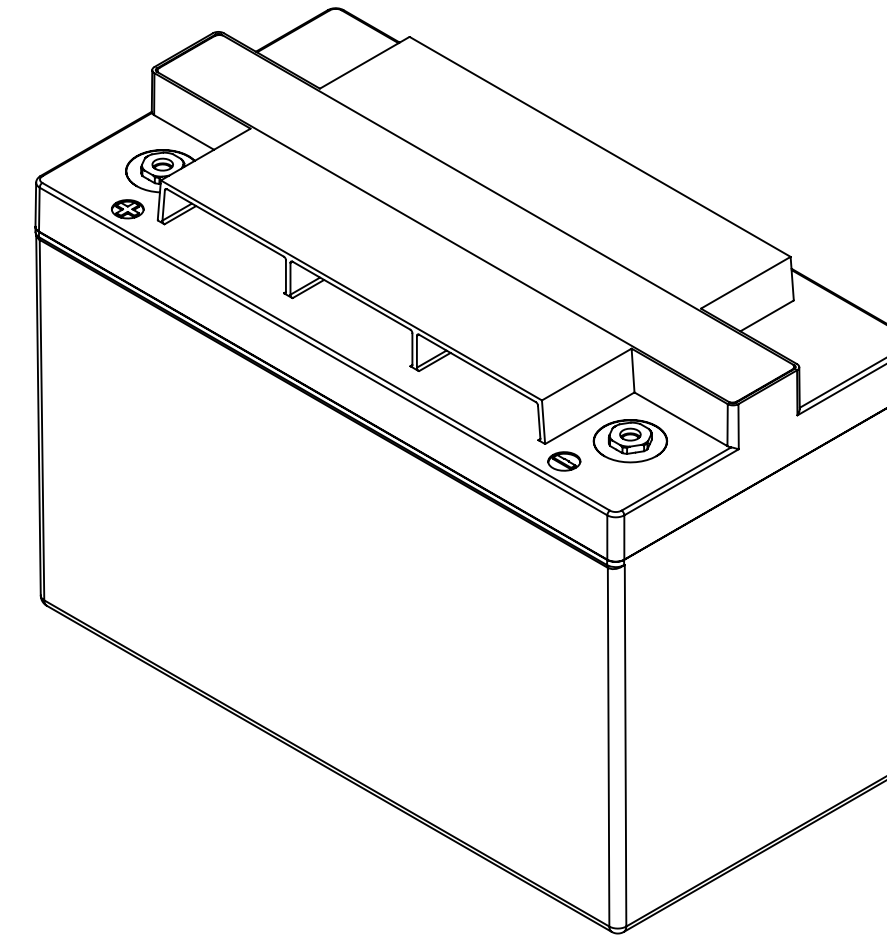
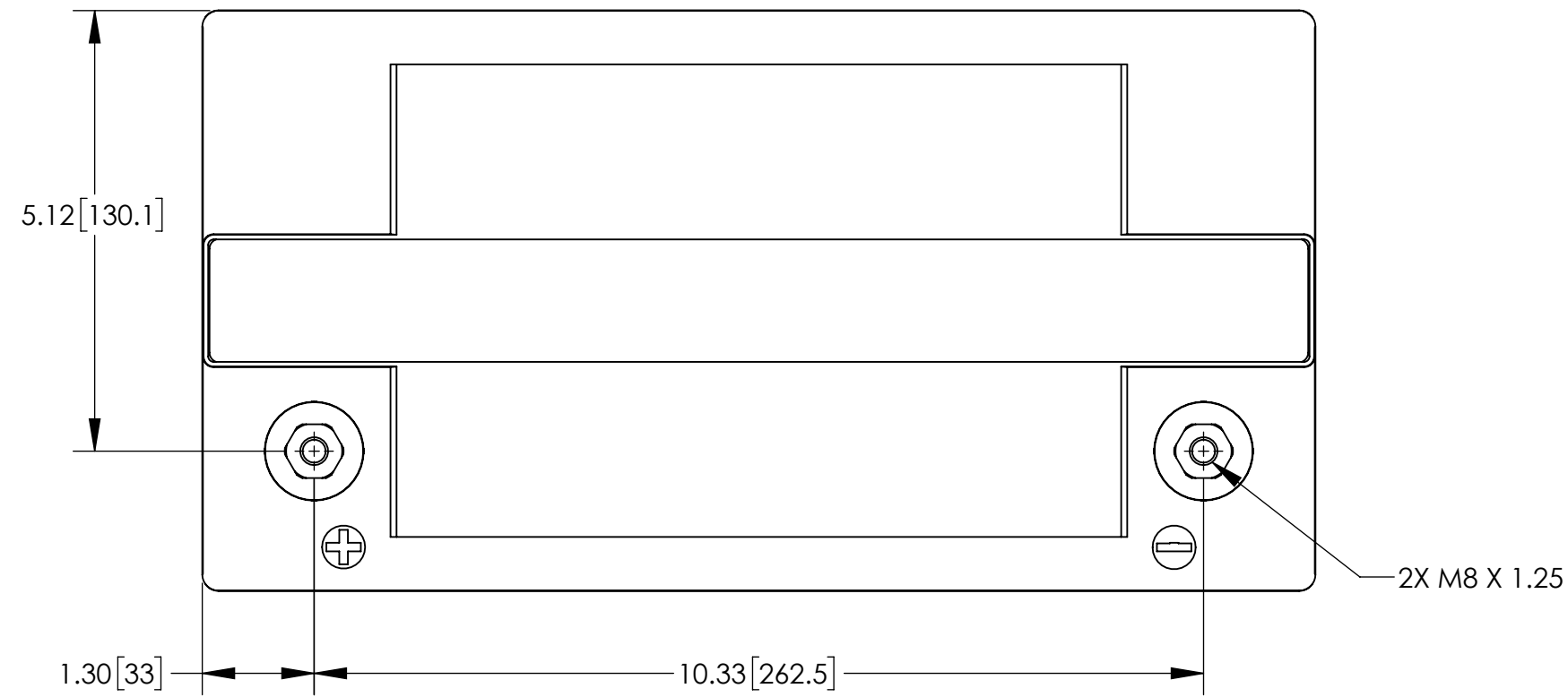

REFERENCE VIEW

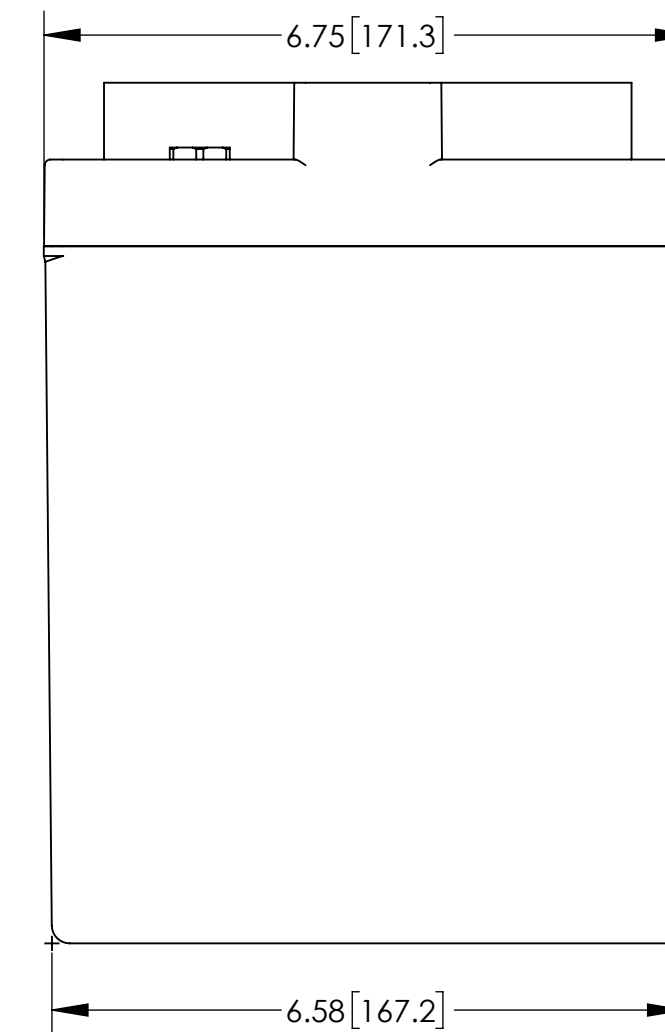

ENVELOPE DRAWING

CAPACITY RATINGS	
PART NUMBER	AGM-12105TG
NOMINAL WEIGHT	64 LBS [29 KG]
AMPERE HOUR CAPACITY @ 20 HOUR 1.75 VOLTS/CELL @ 77°F (25°C)	105 AH
MINUTES OF DISCHARGE @ 25 AMPS 1.75 VOLTS/CELL @ 77°F (25°C)	195 MIN

UNLESS OTHERWISE SPECIFIED DIMENSIONS ARE IN INCHES TOLERANCES ARE:			CONTRACT NO.		CONCORDE BATTERY CORPORATION 2009 SAN BERNARDINO RD, W. COVINA, CA 91790					
FRACTIONS	DECIMALS	ANGLES	APPROVALS		DATE		TITLE			
± 1/32	.XX ± .12 .XXX ± .060	± 1°	DRAWN J.DENDIU		3/3/20		BATTERY, 12 VOLT, AGM-12105TG			
TREATMENT			CHECKED	NS	4/1/20		SIZE	CAGE CODE	DWG NO.	REV
FINISH			APPROVED	PH	4/1/20		C	63017	AGM-12105TG	B
SIMILAR TO			ISSUED	DH	2/21/22		SCALE	1:2	SHEET 1 OF 1	