

NOTES: UNLESS OTHERWISE SPECIFIED

1. SEE DRAWING NO. CB-00391 AND PROCEDURE P-1000 FOR ASSEMBLY AND TEST INSTRUCTION. PROCEDURES AND ASSEMBLY DRAWINGS ARE FOR INTERNAL USE ONLY.
2. ALL TESTING IS PERFORMED IAW BATTERY COUNCIL INTERNATIONAL STANDARDS.
3. ALL DIMENSIONS ARE INCH [MILLIMETER].
4. M8 TERMINAL HARDWARE PROVIDED WITH BATTERY.

REVISIONS			
REV	DESCRIPTION	DATE	APPROVED
A	UPDATED FOR EU 1542 COMPLIANCE	8/16/24	PH

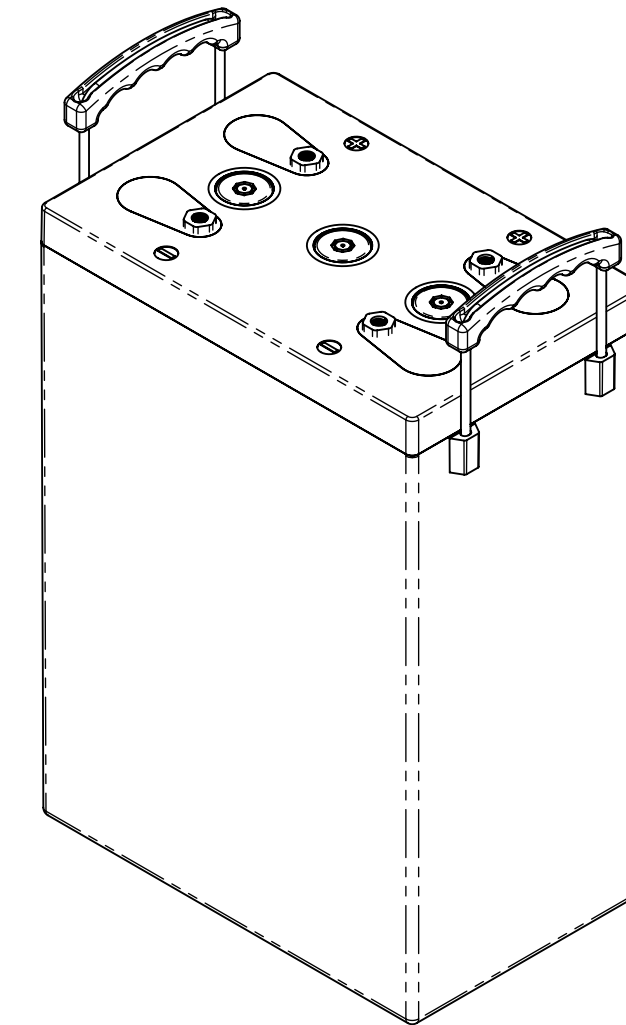
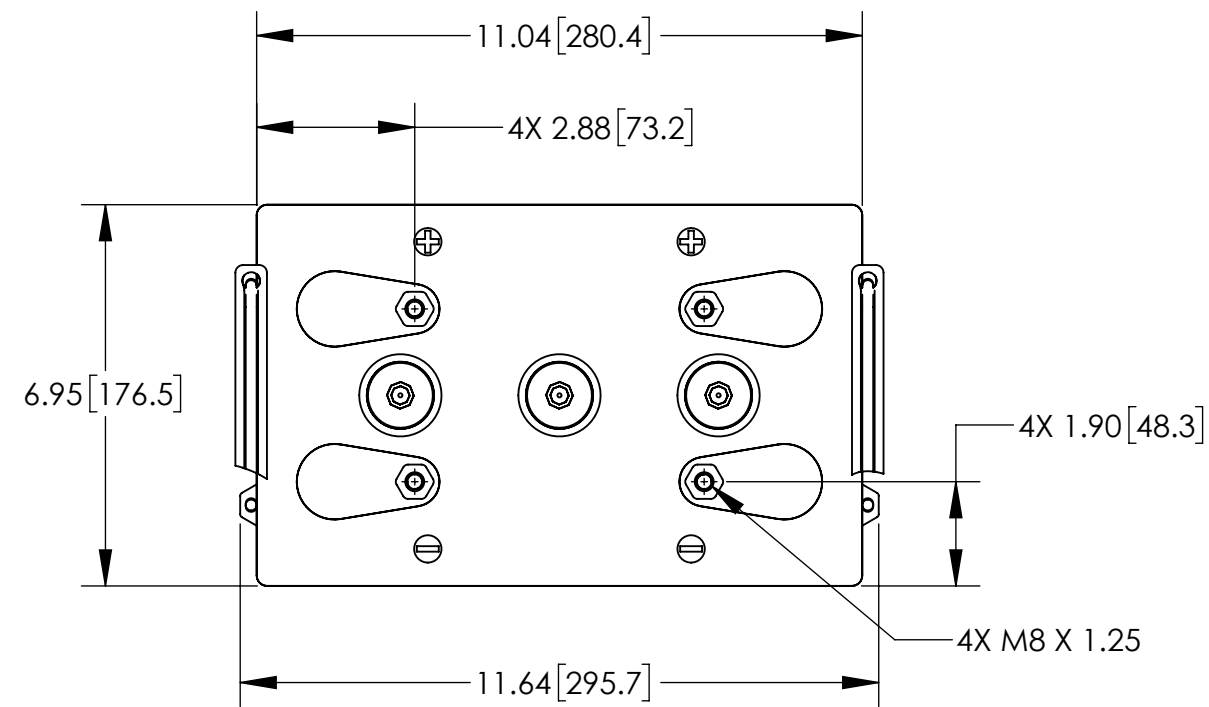

REFERENCE VIEW

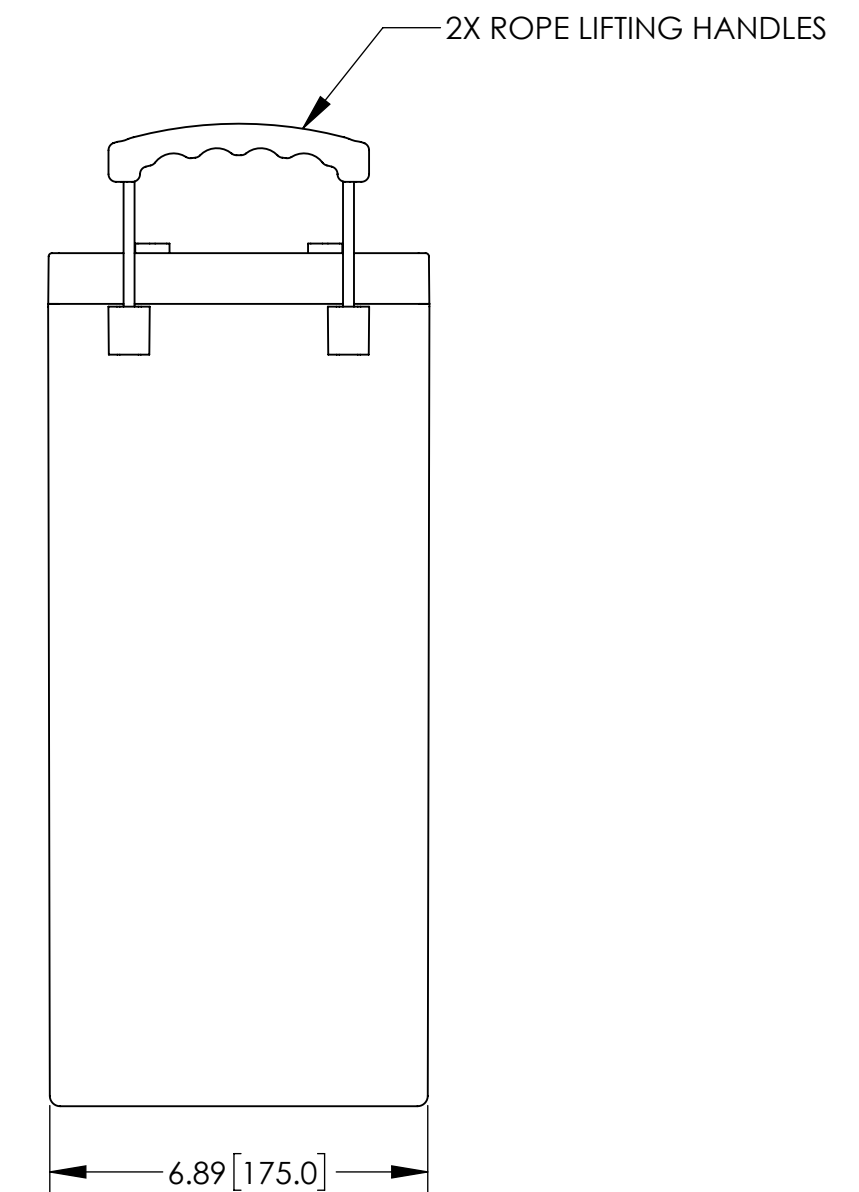
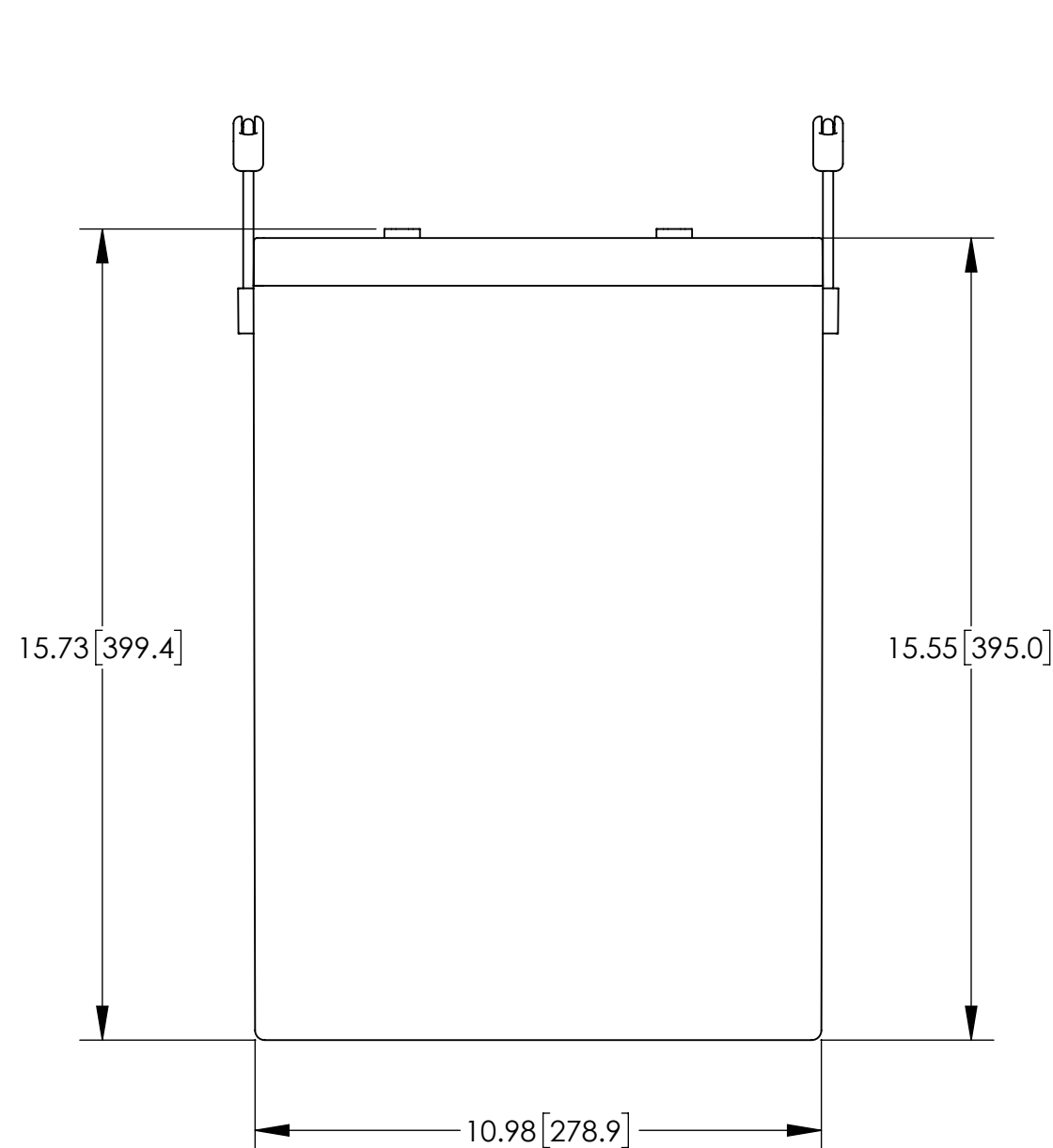

ENVELOPE DRAWING

PART NUMBER	AGM-21200HT
NOMINAL WEIGHT	123 LBS [55.8 KG]
NOMINAL VOLTAGE	2 VOLTS
RATED CAPACITY @ 20 HOUR RATE TO 1.75VPC @ 77°F (25°C)	1200 AH
RATED ENERGY @ 20 HOUR RATE TO 1.75VPC @ 77°F (25°C)	2400 WH
NOMINAL INTERNAL RESISTANCE @ 77°F (25°C)	0.25 MILLIOHMS
MAXIMUM POWER @ 77°F (25°C)	3.9 KW
CAPACITY FADE	TYPICALLY 50% OR 80% AT EOL (USER DEFINED)
POWER FADE	TYPICALLY 50% OR 80% AT EOL (USER DEFINED)
ENERGY ROUND TRIP EFFICIENCY	80%

UNLESS OTHERWISE SPECIFIED DIMENSIONS ARE IN INCHES TOLERANCES ARE:		CONTRACT NO.		CONCORDE BATTERY CORPORATION 2009 SAN BERNARDINO RD, W. COVINA, CA 91790			
FRACTIONS	DECIMALS	ANGLES	APPROVALS	DATE	TITLE		
±1/32	.XX ± .12 .XXX ± .060	± 1°	DRAWN	7/16/09	BATTERY, 2 VOLT, AGM-21200HT		
TREATMENT	NONE	CHECKED	AMIII	7/16/09	SIZE	CAGE CODE	DWG NO.
FINISH	NONE	APPROVED	JBT	7/17/09	C	63017	AGM-21200HT
SIMILAR TO	CALC WT	ISSUED	DH	8/19/24	SCALE	1:3.5	REV A
						SHEET	1 OF 1